



TL 360 | Telescopic Handlers



PERFORMANCE		
Lifting height	(mm)	6010
Rated capacity	(kg)	3000
Capacity at max height	(kg)	3000
Capacity at max. reach	(kg)	1300
Max. reach	(mm)	1293
Crowding force - Tilt	(daN)	5700
Crowding force - Lift	(daN)	3600

WEIGHTS		
Weight (unladen)	(kg)	6110

TRACTION		
Standard tyres		400/70-20

30km/h Option		
1st Gear / High Range	(km/h)	11
2nd Gear / High Range	(km/h)	30

40km/h Option		
1st Gear / High Range	(km/h)	12
2nd Gear / High Range	(km/h)	40

DRIVE SYSTEM		
Transmission		Hydrostatic with electronic regulation
Main Drive		Hydrostatic motor + 2 speed gearbox

ENGINE		
Make / Model		PERKINS / 1104D-44TA
Fuel / Cooling		Diesel
Rated power (DIN 6271) at 2200 RPM	kw (HP)	74.5 (100)
Maximum torque at 1400 RPM	Nm	410
Number of cylinders		4
Displacement	l	4,4

HYDRAULIC SYSTEM		
Pump Type		Gear pump with LS valve
Combined Pump Capacity	(l/min)	100
Working Pressure	(bar)	255

CYCLE TIMES		
Lift time - no load	(s)	6,9
Lower time - no load	(s)	5,0
Telescope in time at max. reach - no load	(s)	5,3
Telescope in time at max. height - no load	(s)	5,3
Telescope out time at max. reach - no load	(s)	5,4
Telescope out time at max. height - no load	(s)	5,4
Crowding time	(s)	3,0
Dumping time	(s)	2,7

BRAKES		
Service Brake		Oil immersed disc
Parking and Emergency Brake		Negative brake with hydraulic command

FLUID CAPACITIES		
Axles and Reduction gears front / rear	(l)	9.1 / 9.1
Engine Oil	(l)	8,5
Fuel Tank	(l)	138
Hydraulic Reservoir	(l)	59

STANDARD FEATURES		
Adjustable Steering Column		
Auxiliary line		
Cab with half-glass window door		
Cushion lift system		
FNR control on joystick		
Front and rear washer/wipers		
Heating, demisting and ventilation		
Hydrostatic Transmission		
Mechanical lock of attachments		
Mechanical Suspension seat		
Progressive Aggravating Movements Arrestor (AMA)		
Roll sunvisor		
ROPS/FOPS operator cab		
Semi-Automatic Wheel Realignment		
Set of Cab worklights		

OPTIONS	
Air conditioning	
Air suspension seat	
ACD	
Back-up alarm	
Basic tow hitch	
Blue lights for henhouses	
Boom Float	
Boom Lights	
Boom Stop	
Boom Suspension*	
Catalytic Muffler	
Coldstart	
Cyclonic Air Pre-filter	
Drawbar coupler tow hitch	
Fan inverter	
Fire Extinguisher	
Cab with full glass window door	
Hyd. Trailer brake valve	
Load Sensing Pump*	
Lockable Fuel Cap	
Manitou tool carriage	
Protective grill for windshield	
Quicktach tool carriage	
Rear Auxiliary	
Rear Electric Auxiliary	
Rear flat mirror	
Rotating Beacon	
Special Color	
Support for vehicle registration plate	
Tool box	
Wheel wedge	

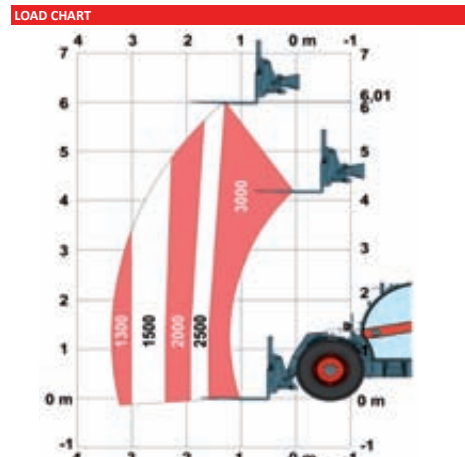

DIMENSIONS	
All dimensions are in mm	

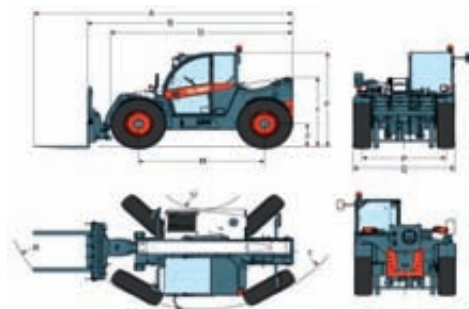

(A)	5874
(B)	4669
(D)	4145
(F)	2374
(G)	1752
(M)	2870
(P)	1895
(Q)	2300
(R)	4805
(T)	3714
(U)	1092

www.bobcat.eu



Bobcat®

Specifications and design are subject to change without notice. Pictures of Bobcat products may show other than standard equipment.

