

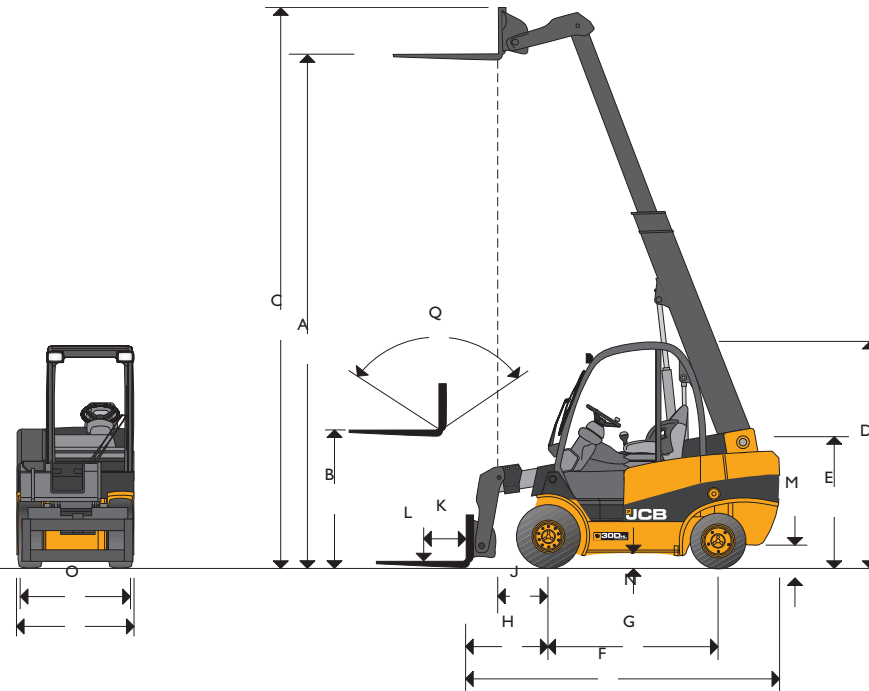

ENGINE FUEL TYPE: DIESEL LIFT CAPACITY: UP TO 3 TONNES



### STATIC DIMENSIONS

Model		TLT30D High-Lift	Model		TLT30D High-Lift		
A	Lift height	mm	5150	J	Distance from c/l of front axle to fork face	mm	540
B	Free lift (standard)	mm	1235	K	Load centre	mm	500
C	Height boom extended	mm	5700	L	Lift capacities (with sideshift)	kg	3000
D	Height of overhead guard (std/low)	mm	2205/2105	M	Ground clearance (lowest point)	mm	125
E	Height of operator's seat (high/low)	mm	1275/1180	N	Ground clearance wheelbase centre	mm	155
F	Length to fork face	mm	3370	O	Fork carriage width	mm	1200
G	Wheelbase	mm	1950	P	Maximum width of machine	mm	1280
H	Distance from c/l of front axle to fork face	mm	790	Q	Carriage tilt total* F/B variable through lift arc	degrees	111



## GENERAL SPECIFICATION

Model		TLT30D High-Lift
Engine type		Diesel
Engine manufacture		Deutz
Engine model		2011-L04W
Engine output (gross power)	kW	46
Engine – rated rpm		2600
Engine – number of cylinders		4
Engine – cubic capacity	cm <sup>3</sup>	3620
Working pressure for attachments	bar	170
Oil flow for attachments	l/min	70
Maximum reach ground level (500mm load centre)	mm	3300
Maximum reach boom horizontal (500mm load centre)	mm	3320
Turning radius	mm	2885
Aisle width 90° stacking 800 x 1200/1000 x 1200	mm	4475/4675
Weight unladen	kg	5380
Travel speed (standard)	km/h	20
Gradeability (laden/unladen)	%	25 : 21
Transmission		TCR
Park brake type		Hand
Shovel rated capacity	m <sup>3</sup>	0.6
Shovel struck capacity	m <sup>3</sup>	0.5
Shovel dump height (30°)	mm	2680
Shovel rollback angle at ground	degrees	33
Shovel width	mm	1385
Tyre PPS (semi-solid), L (pneumatic)		PPS/L
Tyre size front (standard)		27 x 10 x 12
Tyre size rear (standard)		23 x 9 x 10

## STANDARD FEATURES

- Versatile telescopic two-piece boom.
- Superb forward visibility.
- Information display centre (I.D.C) complete with warning lights, hourmeter, fuel gauge.
- JCB 'TCR' torque converter response transmission.
- Comfortable operator's enclosure (structure fully meets international safety standards for (ROPS) Roll-Over Protection and (FOPS) Falling Object Protection).
- Seat belt and hip restraint on fully adjustable seat.
- Load moment indicator.
- Self levelling forks.
- Hose-burst-check valves on tilt, lift, and extension ram circuits.
- Front screen guard.
- Operator's daily checks completed via single easy-access panel, and excellent service access to major components.
- Battery isolator.
- Security etched glazing.
- Working lights front and rear.
- 111 Degree carriage tilt.
- Bucket mode switch.

## OPTIONS

Over 100 build options, including:

- Choice of pneumatic, foam filled or PPS tyres.
- Lightweight re-handling shovel.
- Bagezee 'trapdoor' shovel for loading/filling big bags in single operation.
- Quick disconnect system for easy changing between attachments.
- Sideshift carriage and various forks.
- Range of load guards, attachments, exhaust purification systems, etc.
- Various operator environments: safety mesh to operator's right, glazing to front/rear/top. Full cab with door and heater.
- Low-height cab (for containers check height and floor loadings).
- Vinyl or fabric seat in high/low versions.
- Roadlights.
- Flow divider.

LIFT CAPACITIES

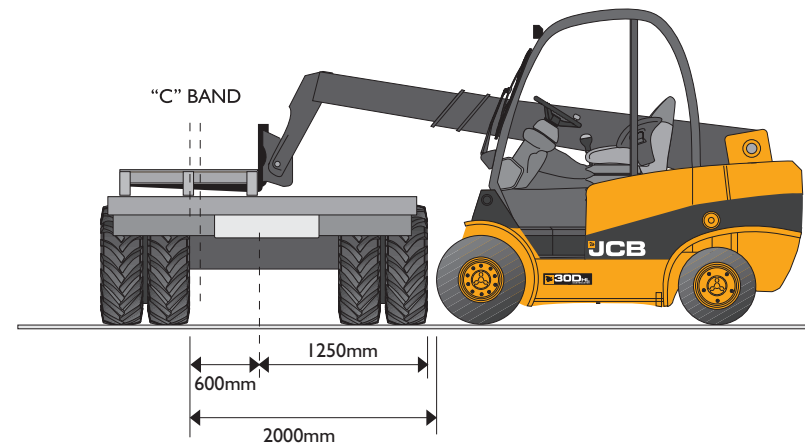
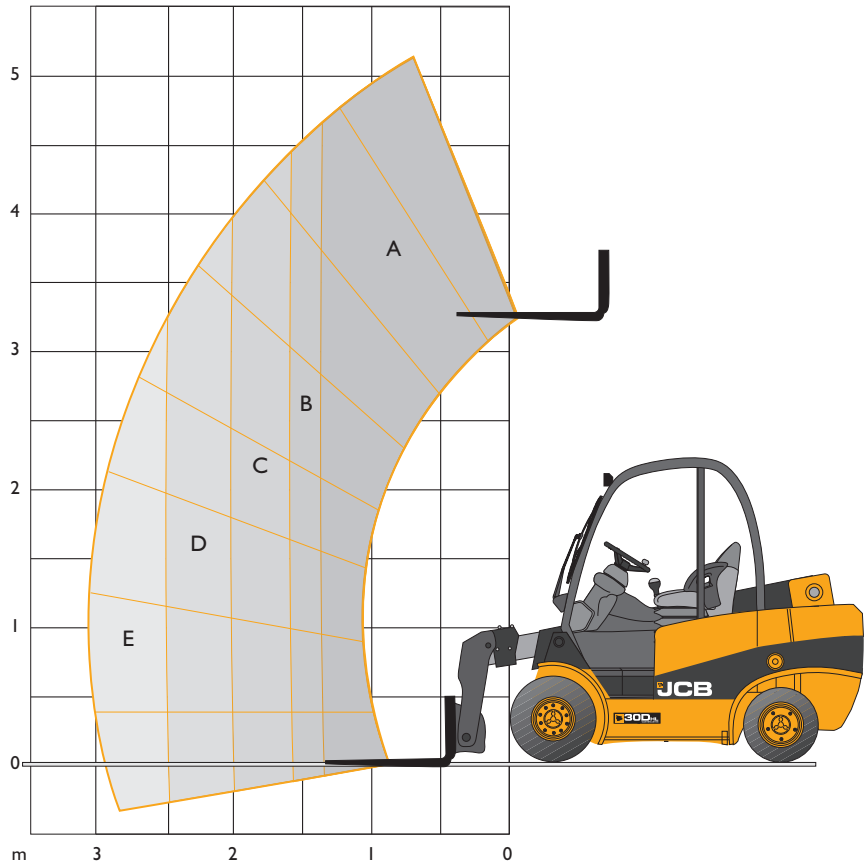

A	B	C	D	E
3000kg	2500kg	1950kg	1500kg	1125kg

## A GLOBAL COMMITMENT TO QUALITY

JCB's total commitment to its products and customers has helped it grow from a one-man business into Britain's largest privately owned manufacturer of backhoe loaders, crawler excavators, wheeled excavators, telescopic handlers, wheeled loaders, dump trucks, rough terrain fork lifts, industrial fork lifts, mini/midi excavators, skid steer loaders, tractors and compaction equipment.

By making constant and massive investments in the latest production technology, the JCB factories have become some of the most advanced in the world.

By leading the field in innovative research and design, extensive testing and stringent quality control, JCB machines have become renowned all over the world for performance, value and reliability.

And with a global sales and service network of more than 650 dealers and agents, we aim to deliver the best customer support in the industry.

Through setting the standards by which others are judged, JCB has become one of the world's most impressive success stories.

